

## **Folding Wheelchair**

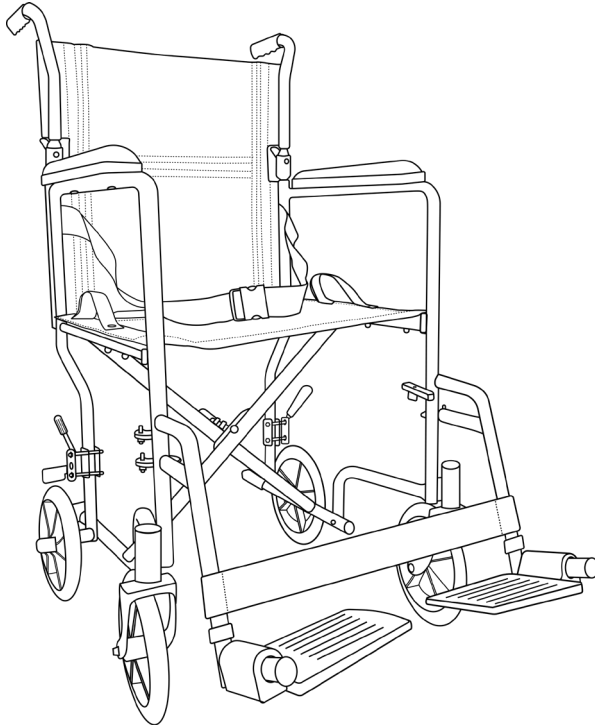

**VA172/BLUE/RED/PINK/HAM**  
**(Aluminium/Steel Range - SGLY00300119)**

**VA171/BLUE/RED/PINK/HAM**  
**(Steel Range - SGLY00400119)**

### **Assembly and Operating Instructions**

This file is available to view and download as a PDF at [www.aidapt.co.uk](http://www.aidapt.co.uk). Sight impaired customers can use a free PDF Reader (such as [adobe.com/reader](http://adobe.com/reader)) to zoom in and increase the text size for improved readability.

## **READ BEFORE USE**

Before using your new transit chair, you and each person that may assist you in its use should take time to read this manual and follow all instructions.

### **PLEASE NOTE:**

Your transit chair has a unique identification serial number. This is located on the main cross brace below the seat canvass and should be used in all correspondence.

Write your serial number here for future reference:

This model is intended for assistance pushing use only and not for wheeling by the person sitting in the Wheelchair.

***The maximum user weight is 115 kg; under no circumstances should this be exceeded***

When folding the chair for transportation in a car the leg rests can be detached and the backrest can be folded.

Before each use please take the time to check your chair for any loose parts.

Any modification to this product without the express permission from Aidapt will invalidate your guarantee.

## **SAFETY SUMMARY**

The following recommendations are made for the safe use of the chair.

***NOTE: Do not assemble or use this equipment without first reading and understanding this instruction manual.***

***The helper should not place all of their weight on the handles by lifting their feet off the floor as this will place adverse strain on the handles.***

If you cannot understand the instructions, please contact Aidapt, a Healthcare Professional or a Dealer before installing this equipment.

- Before using this product, care must be taken to ensure that fittings are secure, the castors/wheels are in good working order, the chair is properly balanced and all wheels must be in contact with the floor at all times during use.
- For safe operation, the following points must be remembered:
  - i. Always observe the limits regarding reaching objects, leaning back, tilting and use of manual brakes, tyres and weights limits. These are dealt with under the section headed Assembly and Use.
  - ii. The footplates are designed only to support the feet while in the seated position. **DO NOT STAND ON THE FOOT PLATES.**
  - iii. **DO NOT USE YOUR WHEELCHAIR AS A TRANSPORT SEAT IN A VEHICLE.**
  - iv. Care should be exercised near open flames or burning cigarettes.
  - v. **WARNING:** Surface areas of your Wheelchair can get hot when the wheelchair is exposed to external sources of heat (eg. sunlight).
- Please now refer to the section on Assembly and use.

## ASSEMBLY

1. First remove all contents from the box.
2. To open the chair, push seat rails and press downwards until the chair is fully opened taking care to keep fingers clear of moving parts (Fig.1).
3. To close the chair, take the centre of the seat fabric at the front and back edges and lift (Fig.2).

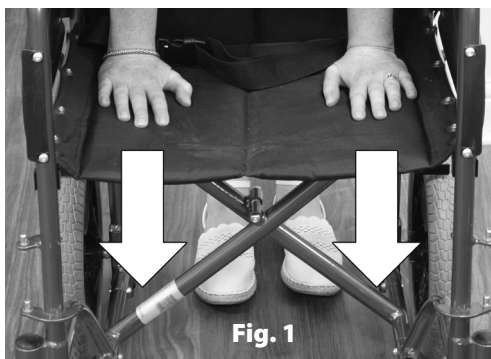

***NB: When opening and closing your chair please keep fingers well away from any possible entrapment areas.***

The only part of the chair that can be adjusted are the leg rests. Ideally your knees should be at 90 degrees with the seat. If you are not sure please contact a healthcare professional or your local Wheelchair dealer for advice.

## **BRAKE OPERATION**

### ***Parking Brakes (Occupant)***

See Fig. 3 which shows the wheelchair with the parking brake not applied. To apply the parking brake push the handle forward as in Fig. 3a until it 'clicks' and this will apply the brake.

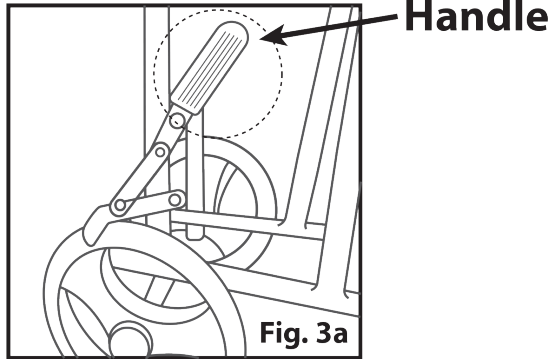
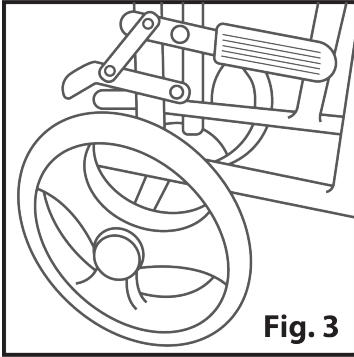

## **BRAKE ADJUSTMENT**

The brakes may need to be adjusted periodically. We would advise that this is done by competent person.

For normal adjustment see Fig. 3c, 'Nut A' needs to be unscrewed and the sleeve moved either upwards or downwards as required to adjust the brakes.

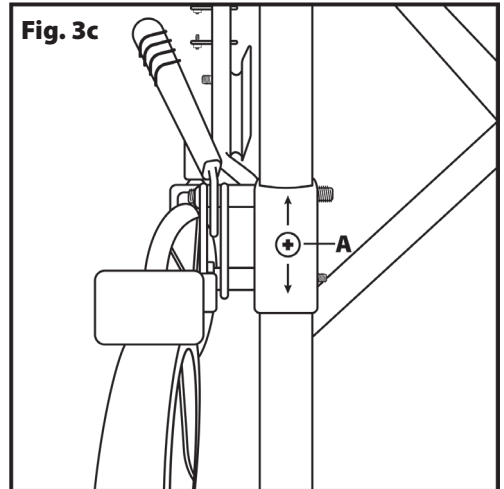

## **USE**

***WARNING: The centre of balance is affected by a change in posture body position or weight distribution.***

Many activities require the chair owner to reach, bend and transfer into and out of the chair. These movements will cause a change to normal balance, centre of gravity and weight distribution of the chair.

The design of your chair enables it to remain stable for normal everyday usage if used correctly in accordance with the recommendations in this manual.

### **1. Reaching/bending forward**

Move the chair as close as possible to the object you wish to reach. Position the front castors so that they are extended as far forward as possible. Fully engage the wheel locks on the rear wheels. Only reach out to take what is within arm's length in normal sitting position. Only the arms should extend beyond the seat of the chair. Do not attempt to reach objects if you have to pick them up from the floor by reaching down between your knees.

### **2. Reaching/bending backwards**

Move the chair as close as possible to the object you wish to reach. Reach back only as far as your arm will extend without changing your seating position. Do not lean over the top of the back upholstery as this could change your centre of gravity and may cause you to tip over.

### **3. Reaching/leaning sideways**

Move the chair as close as possible to the object you wish to reach. Rotate the front castors to a line in the direction you will be reaching. Fully engage the wheel locks on the rear wheels. Do not shift your weight or sitting position towards the object you are reaching as it may cause the chair to tip over.

### **4. Transferring**

Before attempting to transfer in and out of the chair, every precaution should be taken to ensure the gap between the two seats is as small as possible. The chair should be on a smooth, stable and level area. Be sure to fully engage the wheel brakes when transferring in and out of the chair or when in an elevator or chair lift. Turn both castors in the direction of the seat to which you wish to move. Lift up the footplates and fold back the supports to the side. Do not stand on the footplates. It is imperative that the actual transfer procedure be supervised by a certified health care professional until the chair owner is familiar with the procedure.

**Continued on next page**

## 5. Negotiating Obstacles

### 5.1 Approach the obstacle (kerb etc.) front on

The wheelchair should be tilted by the helper until the front castors have passed over the kerbs. The helper must apply downward pressure with their foot to the tip bar (see fig. 5 & 6). The chair should never be tilted by the handles only as this will put adverse strain on the handles. Move the wheelchair forward until the rear wheels touch the kerb and gently lower the front castors over the pavement. Push the lift until the rear wheels have mounted the kerb. The wheelchair should not be lifted by the handles alone.

### 5.2 Upward and Downward slopes (fig. 4)

Always go straight up and down slopes to avoid the possibility of the wheelchair overturning. Avoid steep slopes, which may cause instability.

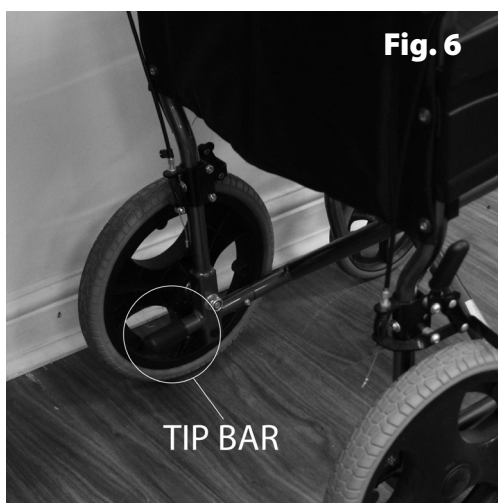
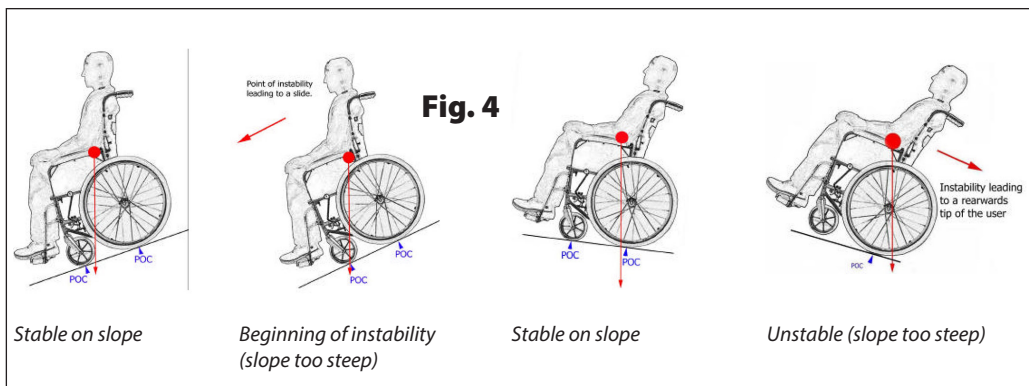

## GENERAL DESCRIPTION

The following diagram shows details of the wheelchair terminology used in this manual.

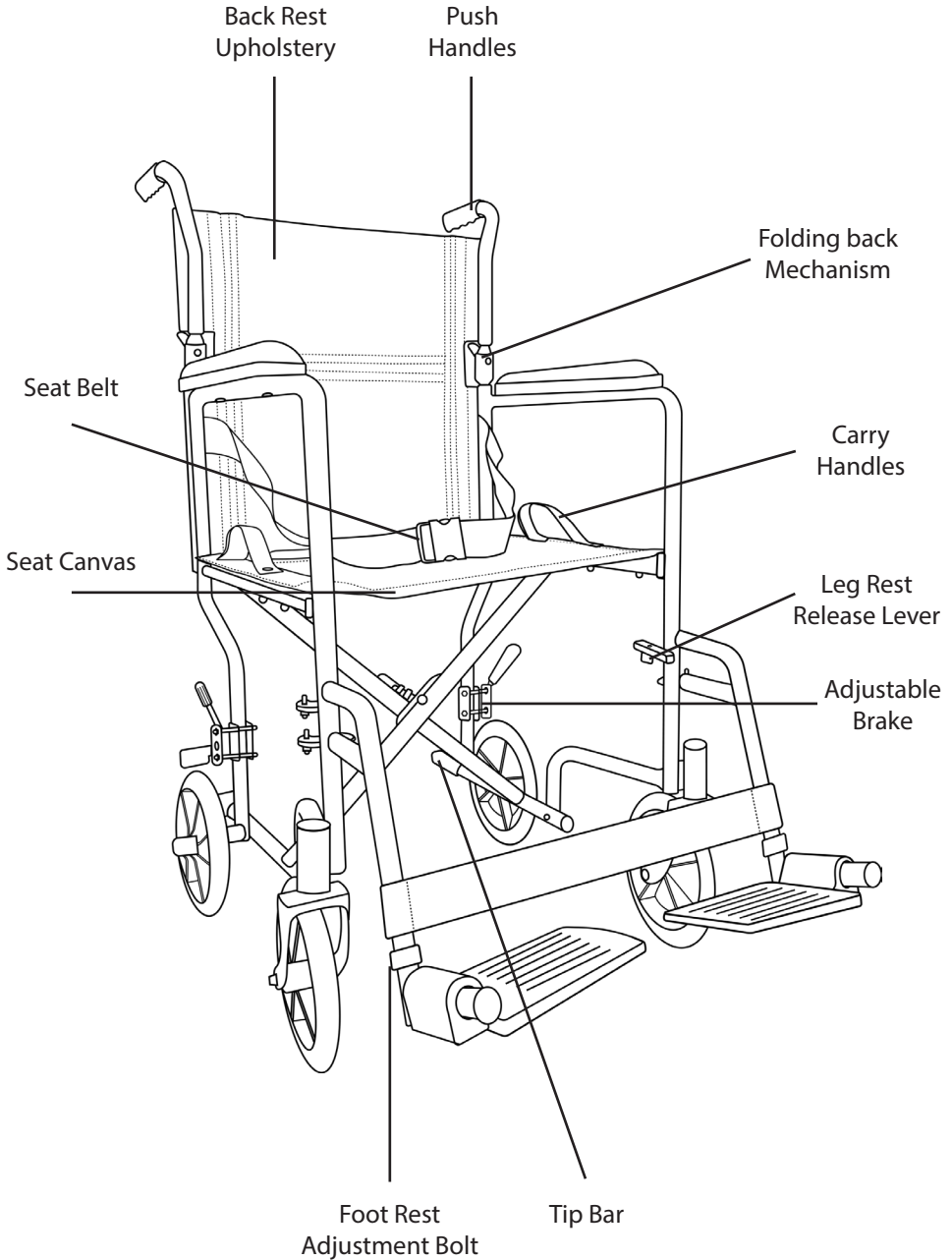

## **1. Backrest**

The adjustable backrest can be folded down by means of a locking mechanism fitted to both sides of the lower part of the backrest pillars. To fold the backrest down, push on both of the black plastic levers, then pull back and down on the top part of the backrest. To return to the original, reverse the procedure, making sure the mechanisms are locked securely.

## **2. Handles**

The handles are designed for the helper to propel the chair. They must not be used solely for lifting the chair over obstructions or kerbs (see negotiating obstacles)

***The helper must not place all of their weight on the handles by lifting their feet off the floor as this will place adverse strain on the handles.***

## **3. Armrest**

PVC pads are fixed onto the armrest for comfort and can be replaced as spare parts.

## **4. Seat Upholstery**

Periodically check the upholstery for signs of tears or sagging. Replace immediately if the seat is damaged. Remember: the seat upholstery is the primary weight supporting material.

## **5. Footplates**

The footplates are intended as a foot support only when you are sitting in the chair. On no account should you stand on the footplates. The heel loops or calf straps (if fitted) can be used to secure the position of the feet. The footplate assemblies can be adjusted in height by loosening the nut of the base of the adjustment tube, positioning the plate at the required height and tightening the nut to secure the assembly. The footplate supports can be swung away to the outside of the chair. To carry out this procedure, pull the release lever towards the front and swing the support to the outside of the chair. If the support is to be removed, lift it upwards. To re-fit and return to the original position, reverse the above procedure.

## **6. Castor and bearing**

The front and rear wheels are solid puncture proof tyres. These should be checked at regular intervals to monitor any wear. Chairs become difficult to steer and propel when surfaces have worn flat. It is recommended that both front tyres are replaced at the same time to avoid one side of the chair from being higher than the other.

The wheel is secured to the castor fork by an axle bolt and axle nut. Periodically, this bolt and nut should be checked and tightened if necessary to allow a snug but free spinning fit. The castor fork swivel on the front wheels allow the chair to be steered in either left or right direction. An adjustment locknut is located under the castor cap. If the locknut is too tight, the chair will be difficult to steer.

## **7. Wheel lock assembly**

These are used to hold the chair in a stationary position, and are fitted on either side of the chair on the back wheels. They should not be used when the chair is moving or to slow it down. They should always be applied together.

To operate, pull the brake lever back towards the back of the chair. This will immobilize the chair. To release the brake, move the lever forwards the front of the chair.



## **8. Cross Bar**

Operation of the cross brace permits the chair to be opened and closed easily. It should be inspected at regular intervals for signs of wear and bending.

# **ROUTINE CHECKS AND MAINTENANCE**

## **1. Upholstery**

Upholstery should be routinely cleaned with a mild soap and water solution. Never use paint remover or thinners on upholstery.

## **2. Metal Parts**

Clean all metal parts with a wax compound such as car wash to maintain finish. Do not use any obtrusive cleanser that will scratch the finish on the chair.

## **3. Cross Brace**

Periodically lubricate the centre bolt on the cross brace with light machine oil.

## **4. Tyres and Wheels**

Examine tyres regularly for wear and replace as necessary. Solid tyres should be replaced when they become loose on the rim or cracks appear which expose the mounting wire groove. Check that the wheels run freely.

## **5. Castors**

Check periodically that the bolt and nut securing the wheel to the castor fork is tight and allows a snug but free spinning fit. If wheels are loose or wobble then consult service personnel.

## **6. Brakes**

Regularly check for effective operation and there is no wear or signs of play.

## **7. General**

Always check before use that the chair folds and unfolds correctly and that movement both backwards and forwards is in a straight line.

## **8. Servicing**

We recommend your chair is fully serviced every twelve months. For parts information please contact Aidapt Bathrooms Limited (details on the back page).

## **9. Recycling of your Wheelchair**

Once the chair has reached its expected service life you can contact Aidapt for disposal.

## **SPECIFICATIONS**

Width (folded) mm .....	245
Width (unfolded) mm .....	590
Net weight Kg (Including Footrests) Aluminium Type.....	10.3
Net Weight Kg (Including Footrests) Steel Type .....	12
Maximum User Weight Kg.....	115
Seat Size WxD mm .....	480x406
Wheel Size mm.....	203
Additional information.....	Folding Backrest

## **SERVICE WARRANTY**

Aidapt Bathrooms Ltd guarantees the product free from defects in material and workmanship for a period of one year.

Should this product be operated under conditions other than those recommended, or any attempts made to service or modify the product, then the warranty is rendered void.

The product you buy may differ slightly from illustrations. This warranty is in addition to, and does not affect your statutory rights.

Our guarantee is administered by our retailers.

If your product arrives damaged, you must contact the retailer from whom you bought it. The retailers contact details will be on the invoice that arrived with the product, or on the email you received when you placed the order. Do not contact Aidapt Bathrooms Ltd, only your retailer can arrange a replacement or refund.

If your product fails within the guarantee period, please contact the retailer from whom you bought it.

If you have received your product and require technical help, please call our help desk on 01744 745 020.

A copy of the instruction leaflet can be downloaded from our website.

Distributed by;

Aidapt Bathrooms Limited, Lancots Lane, Sutton Oak, St. Helens, Merseyside WA9 3EX

t: 01744 745 020

f: 01744 745 001

e: sales@aidapt.co.uk

UK Responsible Person:

SUNGO Certification Company Limited

Address: 3rd Floor, 70 Gracechurch Street, London EC3V 0HR

SRN: 28466



SUNGO Europe B.V.

Fascinatio Boulevard 522, Unit 1.7, 2909VA Capelle aan den IJssel, The Netherlands

SRN: NL-AR-000000247



August 2023