



Programmable Panel Heater



EH1990

500W

EH1992

1000W

EH1994

1500W

EH1996

2000W

User Manual

Please Retain for Future Reference

Updated Manuals Available Online;
www.electrovision.co.uk/search?term=EH1992

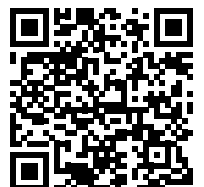

Please note:

For energy conservation purposes this product is only suitable for well insulated spaces

IMPORTANT

Installer and Users please note:

These instructions should be read carefully and left with the user of the product for future reference.

BEFORE USE

You must inspect the appliance including its cable and plug for any signs of damage. If the product is damaged, DO NOT use it, and contact your supplier immediately

PRODUCT SAFETY

- This appliance can be used by children aged from 8 years and above and persons with reduced physical, sensory or mental capabilities or lack of experience and knowledge if they have been given supervision or instruction concerning use of the appliance in a safe way and understand the hazards involved.
- Children shall not play with the appliance.
- Cleaning and user maintenance shall not be made by children without supervision.
- Do not cover. This symbol shown on the casing of the heater means that the heater should not be covered
- For indoor use only.
- Do not use in bathrooms, wet rooms or other damp locations
- Do not use this product with an extension lead or multi plug adaptor.
- Do not use in Boats, Caravans or other similar locations.
- Please allow for a 50 cm safe area around the top, front and sides.
- Do not place the mains lead beneath a carpet or rug.
- Do not place directly under curtains, drapes or other soft furnishings
- Do not place the heater below a socket outlet
- The air vents on the bottom of this product must not be blocked at any time
- Only use the feet provided when using the heater in free-standing mode
- There must be a minimum air gap at the bottom of the heater when wall mounting of at least 80mm above the skirting board
- Do not use the heater in locations where paint, petrol or other flammable liquids are used or stored
- Please ensure the heater is switched off and unplug when not in use, also keep unplugged before assembly or disassembling parts
- Do not use the heater for other than its intended use
- Do not insert any object into the heater through the grilles. This may damage the heater or result in overheating or electric shock.
- Check the product regularly including the mains lead for damage. If any damage is detected stop using it immediately and consult your supplier.
- Only use this product on a flat, stable surface
- Do not leave this product unattended when in use.
- For domestic use
- There are no user serviceable parts in this product
- The permanent installation of this unit should only be undertaken by a competent person.
- Do not touch the case when in use - HOT
- Allow to cool down before moving
- Switch off and disconnect from the mains before cleaning

IMPORTANT

Only attach to a wall using the brackets provided. The unit must be installed in a level vertical position with the control panel at the top (see fig. 1)

Leave enough room at the unit to allow air to freely move through the product (at least 80mm above skirting board level)

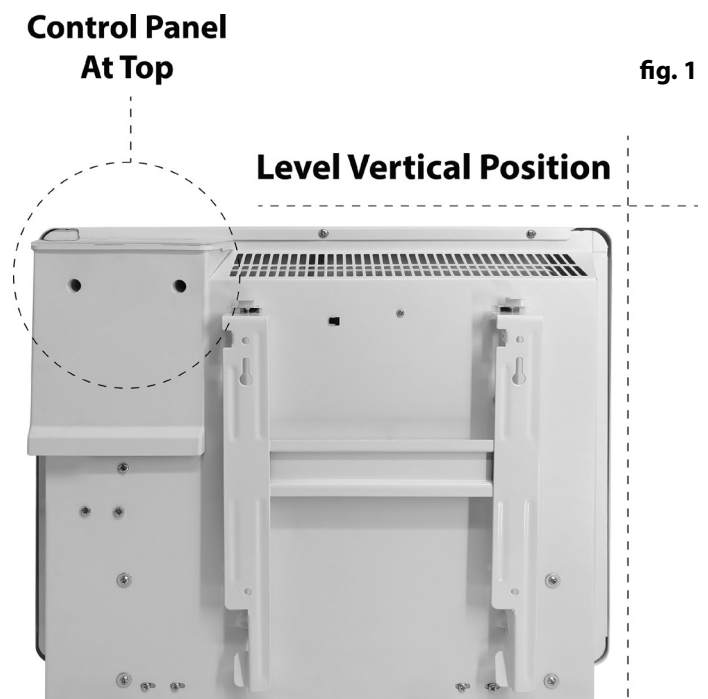

ASSEMBLY/INSTALLATION

The unit must be switched off and disconnected

Free Standing:

1. Attach the two castor-wheel brackets to the underneath of the heater (see fig. 2) using the eight M4x8mm screws (four in each bracket). The longer side of the bracket goes at the back of the heater (see fig. 3 and fig. 4)

fig. 2

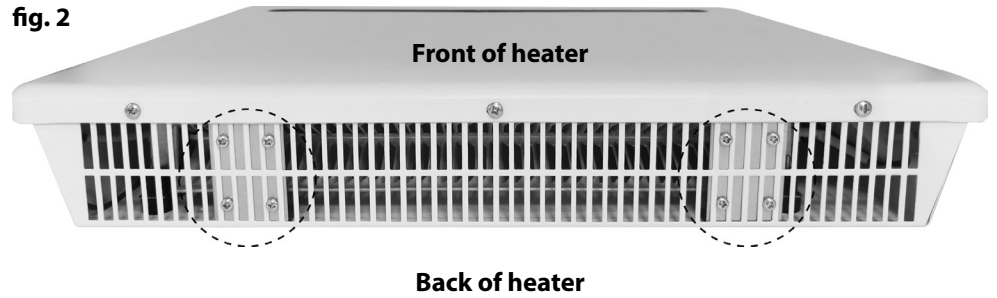

fig. 3

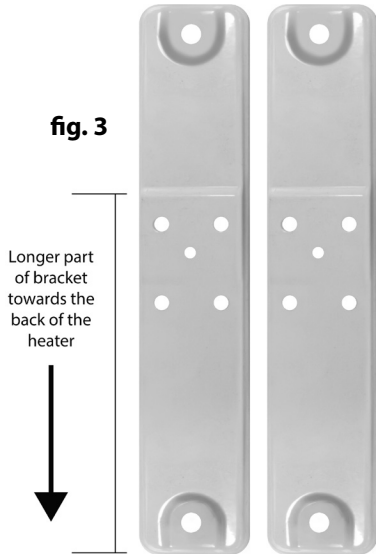
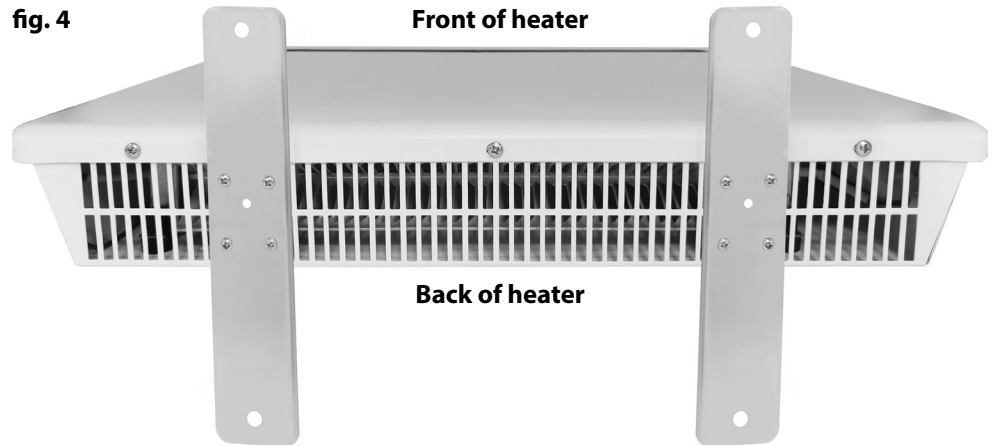

fig. 4



2. Attach two castor-wheels to each bracket using the dome-nuts provided (see fig.5 and fig. 6)

fig. 5



fig. 6



ASSEMBLY/INSTALLATION (CONTINUED)

Wall Mounting:

Note: This item is fitted with a tip over switch. It must be installed in a level upright position with the Control panel at the top (see fig. 7)

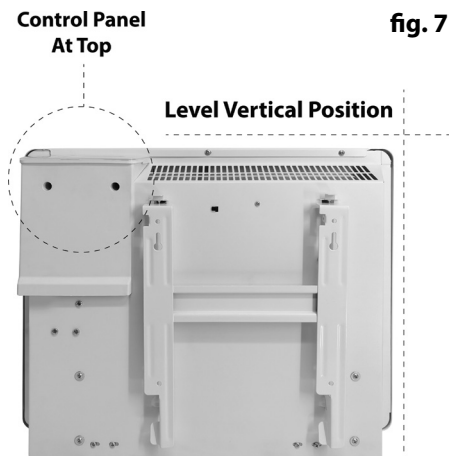

1. Remove the bracket from the back of the unit by depressing the two clips (see fig. 8)

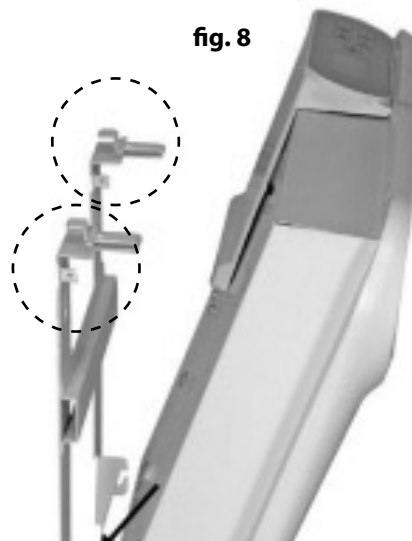

2. Using the bracket as a template, and taking note of the safety instructions on page 1, fix the bracket to a strong stable surface. Fixings are supplied but the installer must be sure these are suitable for the surface this is being fixed to.

3. Holding the unit firmly offer it back to the bracket in a slight upwards motion (see fig. 9), making sure the unit is firmly in place and that the clips are secure before letting go (see fig. 10)

4. The unit and its bracket should be periodically checked for wear and damage. If any is detected then disconnect from the mains immediately and contact your supplier.



OPERATION

Control Panel Overview

A Help Video Is Available Online;
www.electrovision.co.uk/search?term=EH1992

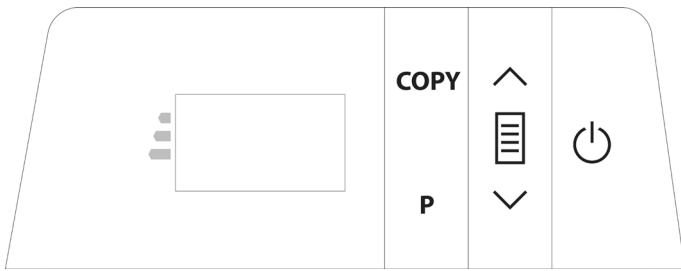

Control Panel Symbol	Function
	Main power switch (side of unit)
	On/Off key
COPY	Program copy key
P	Program mode
	Mode key
	Up key: to set the temperature or time. Holding the button for 3 seconds will scroll the temperature
	Down key: to set the temperature or time. Holding the button for 3 seconds will scroll the temperature

LCD Display Symbol	Function
	Comfort mode (Temperature range 5-35°C)
	Eco mode = Comfort mode -3.5°C
	Anti-frost mode (Temperature set at 7°C)
	Heating indicator
P	Programming mode (Set the heater with a program)
	Keypad lock
	Open window function
COPY	Copy a daily program
	Behavioural indicator. To raise awareness of the risk of over consumption when setting the temperature. <ul style="list-style-type: none"> • Green means normal consumption (below 19.5°C) • Yellow means high consumption (from 19.5°C to 24°C) • Red means very high consumption (above 24°C)

OPERATION (MODE SELECTION)

Comfort Mode:



Press Mode key to choose comfort mode In this mode, you can use the up key and the down key to set the temperature from 5-35°C. Holding up or down for 3 seconds will scroll the temperature. After you set the temperature in comfort mode, wait a few seconds, the temperature on the screen will flash and then remain constant. The temperature is now set.

The behavioural indicator raises awareness of the risk of over consumption. The arrow indicating the colour changes depending on the set temperature;

- Green means normal consumption (below 19.5°C)
- Yellow means high consumption (from 19.5°C to 24°C)
- Red means very high consumption (above 24°C)

OPERATION (MODE SELECTION)

ECO Mode:

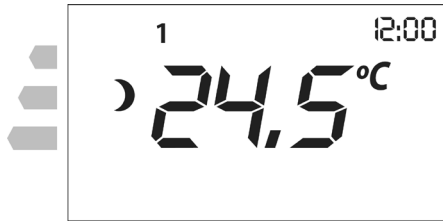

In ECO mode, the temperature cannot be set. The heater will decrease 3.5°C from the current comfort temperature. For example, if the temperature is set to 19°C in comfort mode, the ECO mode temperature will be 15.5°C.

Anti-Frost Mode:

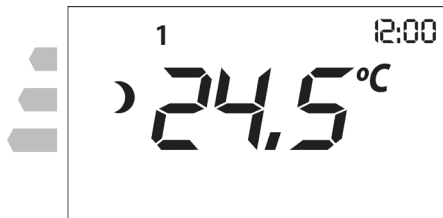

The temperature in anti-frost mode is always 7°C and cannot be set by the user.

4 Preset Modes:

The display will show the preset mode number from P1 to P4

Preset	Schedule	
P1	From 0H to 5H: ECO Mode From 6H to 8H: Comfort Mode From 9H to 15H: ECO Mode From 16H to 23H: ECO Mode	<p>The display shows a '1' in the top left, '12:00' in the top right, a moon icon on the left, and 'P1' in the center. Below the display is a bar chart with markers at 0, 4, 8, 12, 16, 20, and 23h.</p>
P2	From 0H to 5H: ECO Mode From 6H to 8H: Comfort Mode From 9H to 11H: ECO Mode From 12H to 13H: Comfort Mode From 14H to 15H: ECO Mode From 16H to 23H: Comfort Mode	<p>The display shows a '1' in the top left, '12:00' in the top right, a sun icon on the left, a moon icon below it, and 'P2' in the center. Below the display is a bar chart with markers at 0, 4, 8, 12, 16, 20, and 23h.</p>
P3	From 0H to 7H: ECO Mode From 8H to 23H: Comfort Mode	<p>The display shows a '1' in the top left, '12:00' in the top right, a sun icon on the left, and 'P3' in the center. Below the display is a bar chart with markers at 0, 4, 8, 12, 16, 20, and 23h.</p>
P4	From 0H to 2H: Comfort Mode From 3H to 9H: ECO Mode From 10H to 23H: Comfort Mode	<p>The display shows a '1' in the top left, '12:00' in the top right, a sun icon on the left, and 'P4' in the center. Below the display is a bar chart with markers at 0, 4, 8, 12, 16, 20, and 23h.</p>

OPERATION (PROGRAMME MODE)



You can program the working mode for each hour of the day for a week.

When you first enter the P mode you will need to set the current day and the time first.

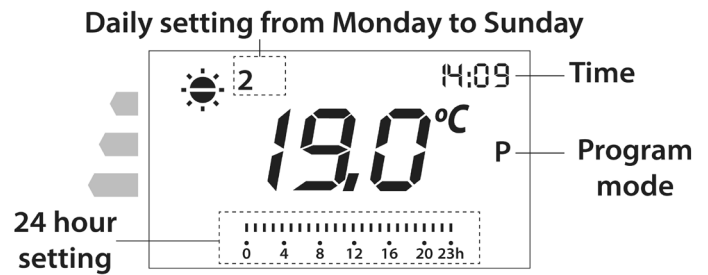



1. Press Mode key until P appears on the screen
2. Press P key to enter into Program setting, the day symbol will flash (1=Monday, 2=Tuesday, 3=Wednesday, 4=Thursday, 5=Friday, 6=Saturday, 7=Sunday)



Current Day Selection:



1. Set the current day (1 to 7, 1=Mon, 2=Tues etc.) with the up key  or the down key 
2. Press **P** key again to confirm

Setting the time:

3. After pressing **P** key to confirm the selected day, the hour position digit will flash. Set the current hour by pressing the up key  or the down key 
4. Press **P** key again to confirm the hour
5. The minutes will now flash, set the minutes by pressing the up key  or the down key 
6. Press **P** key again to confirm the minutes

Setting mode selection for each hour for a week:

After you have set the time, the unit will enter the 24 hour, 7 day week setting

1. The number 1 is indicating that the settings for Monday are being programmed
2. Press Mode key to choose the working mode, comfort or ECO. Comfort symbol  or ECO symbol  will be displayed.
3. Press the up key  to move to the next hour segment (0H/1H/2H/3H...etc. will display)
4. Press **P** key to save the setting for Monday and move to Tuesday (the number 2 will appear)
5. Repeat steps 2 to 4 to set all 7 days.

Copy Function:

Press **COPY** key to copy the program when you have programmed the whole day. Press the up key  to choose the day you wish to copy and then press **COPY**. This will copy the whole days settings and the **COPY** symbol will disappear



When all 7 days have been programmed, press **P** key again and the heater will run as programmed.

OPEN WINDOW FUNCTION

Activate the open window function by long pressing the  and  keys for 3 seconds. The  symbol will display. Repeat to deactivate the open window function.

In open window mode, if the heater detects a drop in the room temperature of 7°C within 30 minutes. the heater will switch to Anti-Frost mode.

KEYPAD LOCK FUNCTION

By long pressing the  and  buttons at the same time, for 3 seconds the function keys on the control panel will be locked and the lock symbol  will display on the screen. Repeat the above steps to unlock the keypad.

Please note: The on/off button the side of the unit cannot be locked.

SCREEN SLEEP MODE

After a period of 60 seconds inactivity the display on the control panel will completely dim. The screen will return to full brightness if any of the buttons on the control panel are pushed.

OPERATING COSTS

At time of going to press, the average cost of electricity is £0.27 per unit (kilowatt-hour). The amount you are being charged will be shown on your electricity bill. At this cost, the running costs will be as follows:

EH1990 500W	£0.14 per hour
EH1992 1000W	£0.27 per hour
EH1994 1500W	£0.41 per hour
EH1996 2000W	£0.54 per hour

These figures apply with the temperature programmed to its highest setting. The running costs will be lower if programmed to a lower temperature, or if the ambient temperature is higher

MAINTENANCE

Before cleaning, turn the heater off, and disconnect from the mains supply. The heater may then be cleaned using a slightly damp cloth with a drop of washing-up liquid to remove any dust or dirt from the case. Do not use stronger detergents or solvents as these may damage the plastic. If the mains lead is damaged, it must be replaced by the manufacturer or an authorised service centre. If the mains plug needs to be replaced, proceed as follows:

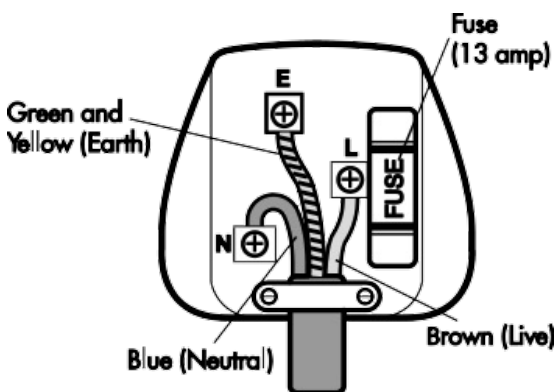

- Connect the brown wire to the terminal labelled "L".
- Connect the blue wire to the terminal labelled "N".
- Connect the green/yellow wire to the terminal labelled with the earth symbol or "E".
- Make sure that the cord-grip is positioned correctly (over the outer sheath of the cable) and it fully tightened.

FAULT FINDING

The heater has an overheat protection switch, which disconnects the power if the element gets too hot. The usual reason for this is because the air-flow has been obstructed. If the heater ceases to operate, leave it for 20 minutes to cool down, then check that the grilles are not being obstructed. Switch back on, and check that the unit is operating normally. If not, contact an authorised service agent for repair

If the keypad is unresponsive, and the display shows [_ _] then the panel has been locked. Press + and – together and hold for 3 seconds to unlock it.

DISPOSAL AND RECYCLING

You must not dispose of this appliance with domestic household waste. Most local authorities have specific collection system for appliances and disposal is free of charge to the end-user. When replacing an existing appliance with a similar new appliance your retailer may take the old appliance for disposal.

TECHNICAL SPECIFICATION

Code	Dimensions Wall Mounting (mm)	Dimensions Floor Standing (mm)	Weight (kg)	Power Supply	Power Consumption (kW)	Operating Current (A)
EH1990	400x400x96	400x445x264	3.59	230V	0.5	2.2
EH1992	500x400x96	500x445x264	4.39	230V	1	4.3
EH1994	640x400x96	640x445x264	5.29	230V	1.5	6.5
EH1996	940x400x96	940x445x264	7.30	230V	2	8.7

Model Number		EH1990/EH1992/EH1994/EH1996		
Item	Symbol	Value	Unit	
Heat Output				
Nominal Heat Output	P nom	0.5/1.0/1.5/2.0	kW	
Nominal Heat Output (Indicitive)	P min	0.5/1.0/1.5/2.0	kW	
Maximum Continuous Heat Output	P max, c	0.5/1.0/1.5/2.0	kW	
Auxiliary Electricity Consumption				
At nominal heat output	el _{max}	0.5/1.0/1.5/2.0	kW	
At minimum heat output	el _{min}	0.5/1.0/1.5/2.0	kW	
At standby mode	el _{SB}	0.00023	kW	

Type of heat input, for electric storage local space heaters only (single select)	
manual heat charge control, with integrated thermostat	No
manual heat charge control with room and/or outdoor temperature feedback	No
electronic heat charge control with room and/or outdoor temperature feedback	No
fan assisted heat output	No

TECHNICAL SPECIFICATION

Type of heat output/room temperature control (single select)	
single stage heat output and no room temperature control	No
Two or more manual stages, no room temperature control	No
with mechanic thermostat room temperature control	No
with electronic room temperature control	No
electronic room temperature control plus day timer	No
electronic room temperature control plus week timer	Yes

Other control options (multiple selections possible)	
room temperature control, with presence detection	No
room temperature control, with open window detection	Yes
with distance control option	No
with adaptive start control	No
with working time limitation	No
with black bulb sensor	No
Contact Details	Prem-i-Air Appliances Ltd, Lancots Lane, St Helens, WA9 3EX

SERVICE WARRANTY

Prem-i-Air guarantees the product free from defects in materials and workmanship for a period of twelve months. Should this appliance be operated under conditions other than those recommended, at voltages other than the voltage indicated on the appliance, or any attempts made to service or modify the appliance, then the warranty will be rendered void. The product you buy may sometimes differ slightly from illustrations. This warranty is in addition to, and does not affect, your statutory rights.

Our guarantee is administered by our retailers.

If your product arrives damaged, you must contact the retailer from whom you bought it. The retailer's contact details will be on the invoice that arrived with the product, or on the e-mail you received when you placed the order. Do not contact Prem-i-air, only your retailer can arrange a replacement.

If your product fails within the guarantee period, firstly read the "fault finding" section of this manual, because temperature and weather conditions can affect the performance of certain products. If the product needs to be repaired or replaced, you must contact the retailer from whom you bought it.

The retailer's contact details will be on the invoice that arrived with the product, or on the e-mail you received when you placed the order.

If you have just received your product and require technical help in using it, please call our Help Desk on (0845) 459 4816

If you have any other technical queries about the product, please call our Help Desk on (0845) 459 4816.

**Prem-i-Air Appliances Ltd.,
Lancots Lane, Sutton,
St. Helens, Merseyside.
WA9 3EX
www.electrovision.co.uk**

Updated Manuals Available Online;
www.electrovision.co.uk/search?term=EH1992

